



CHRONOMITE HIGH CAPACITY INSTANT-TEMP WATER HEATERS INSTALLATION AND OPERATION INSTRUCTIONS (277V Models)

(Before installation, compare electrical requirements needed for the model of heater selected)

TABLE 1 – Electrical Specifications

2 Module Heaters (60-80 amp)

| Model | Wattage | Total Amps | 1Φ Voltage | Circuits | Single Pole Circuit Breakers | |
|------------------|---------|------------|------------|----------|------------------------------|-----------------|
| | | | | | Intermittent Duty | Continuous Duty |
| ER-60x/277_16600 | 16,600 | 60 | 277 | 2 | Qty 2 x 30 amp | Qty 2 x 40 amp |
| ER-80x/277_22200 | 22,200 | 80 | 277 | 2 | Qty 2 x 40 amp | Qty 2 x 50 amp |

3 Module Heaters (90-120 amp)

| Model | Wattage | Total Amps | 1Φ Voltage | Circuits | Single Pole Circuit Breakers | |
|-------------------|---------|------------|------------|----------|------------------------------|-----------------|
| | | | | | Intermittent Duty | Continuous Duty |
| ER-90x/277_24900 | 24,900 | 90 | 277 | 3 | Qty 3 x 30 amp | Qty 3 x 40 amp |
| ER-120x/277_33300 | 33,300 | 120 | 277 | 3 | Qty 3 x 40 amp | Qty 3 x 50 amp |

x = (L)-Low Activation
(S)-Standard Activation
(H)-High Activation

HCH Instant-Temp Specifications:

Dimensions: 15-1/4" x 17-1/2" x 6-1/4"

Weight: 24 LBS (2 module) / 26 LBS (3 module)

Materials:

- Rugged steel housing and cover
- Celcon plastic element assembly with nichrome coils

Minimum Operating Pressure: 25 PSI

Maximum Operating Pressure: 80 PSI

Maximum Pressure: 150 PSI

No pressure relief valve needed, unless required by local code.

Maximum Operating Temperature: 140°F

Listings: UL, UPC, CE, ETL-c

Mounted Unit

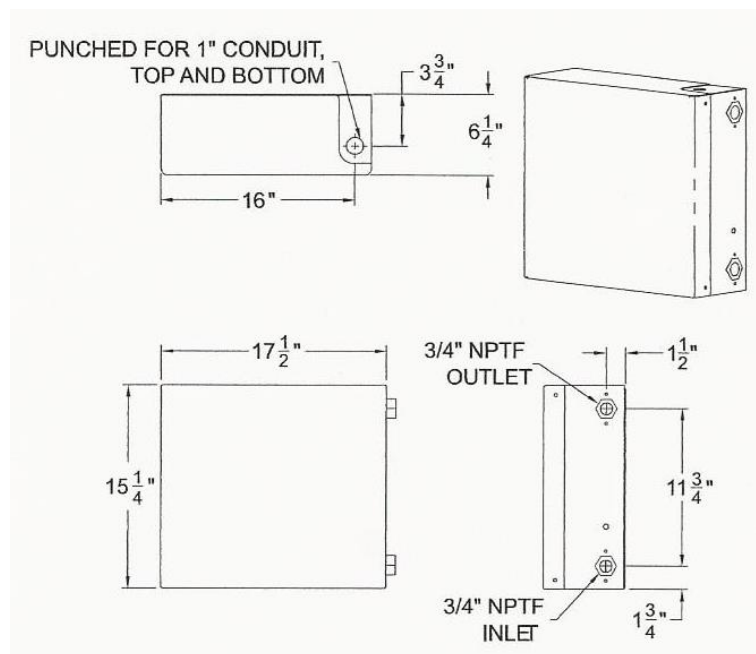

TABLE 2 – Flow Switch Activation

| Flow Switch Activation | <u>2 Module Heaters</u> | <u>3 Module Heaters</u> |
|--------------------------------|--------------------------------|--------------------------------|
| Low Activation (L) | 0.35 GPM | 0.35 GPM |
| Standard Activation (S) | 0.80 GPM | 1.20 GPM |
| High Activation (H) | 1.80 GPM | 2.80 GPM |

THE MANUFACTURER OF THIS WATER HEATER WILL NOT BE LIABLE FOR ANY DAMAGES CAUSED BY THE FAILURE TO FOLLOW THESE INSTALLATION AND OPERATION INSTRUCTIONS.

CAUTION: BEFORE BEGINNING THE INSTALLATION:

- 1. Turn off all circuit breakers to avoid dangerous electrical shocks. This heater is supplied by multiple circuit breakers.**
- 2. Turn off water supply.**

INITIAL INSTALLATION:

1. Before installation, compare electrical requirements needed for the model of heater selected in Table 1.
2. Remove heater cover. Mount unit horizontally flush against the wall (See Fig. 1). Water connections will be either on right hand or left hand side only. If water connections are at top or bottom, heater is not in correct position. Mount with four screws through the mounting holes located on the base plate housing using molly anchors or fasteners. **CAUTION:** Heating elements may burn out if unit is not mounted with heater modules horizontally.
3. Insure placement of heater allows 5" clearance for screwdriver access to remaining 3 sides of heater to allow cover removal, and future servicing if needed. (See Fig. 1).
4. Attach electrical conduit and fittings to the 1" electrical access hole on either top or bottom of base plate. Access hole can be enlarged to next trade size if needed. Do not attaching wiring yet.
5. Connect plumbing. Use ¾ inch tapered national pipe thread at cold-water inlet and hot water outlet (See Fig. 1). Use unions and valve(s) for ease of installation and possible servicing. Use Teflon tape or pipe sealing compound. Do not apply heat to these fittings, as damage to the heater modules will occur and void warranty. Rough out plumbing with heater in place, then remove heater during soldering of connections.
6. Run water through the unit to expel all air bubbles. Cycle downstream faucet 10x to assist removing air bubbles. This will also pressurize unit. Check for leaks at all fitting joints and also inside heater.
7. If no leaks, proceed to Electrical Installation Section and Figure 2.

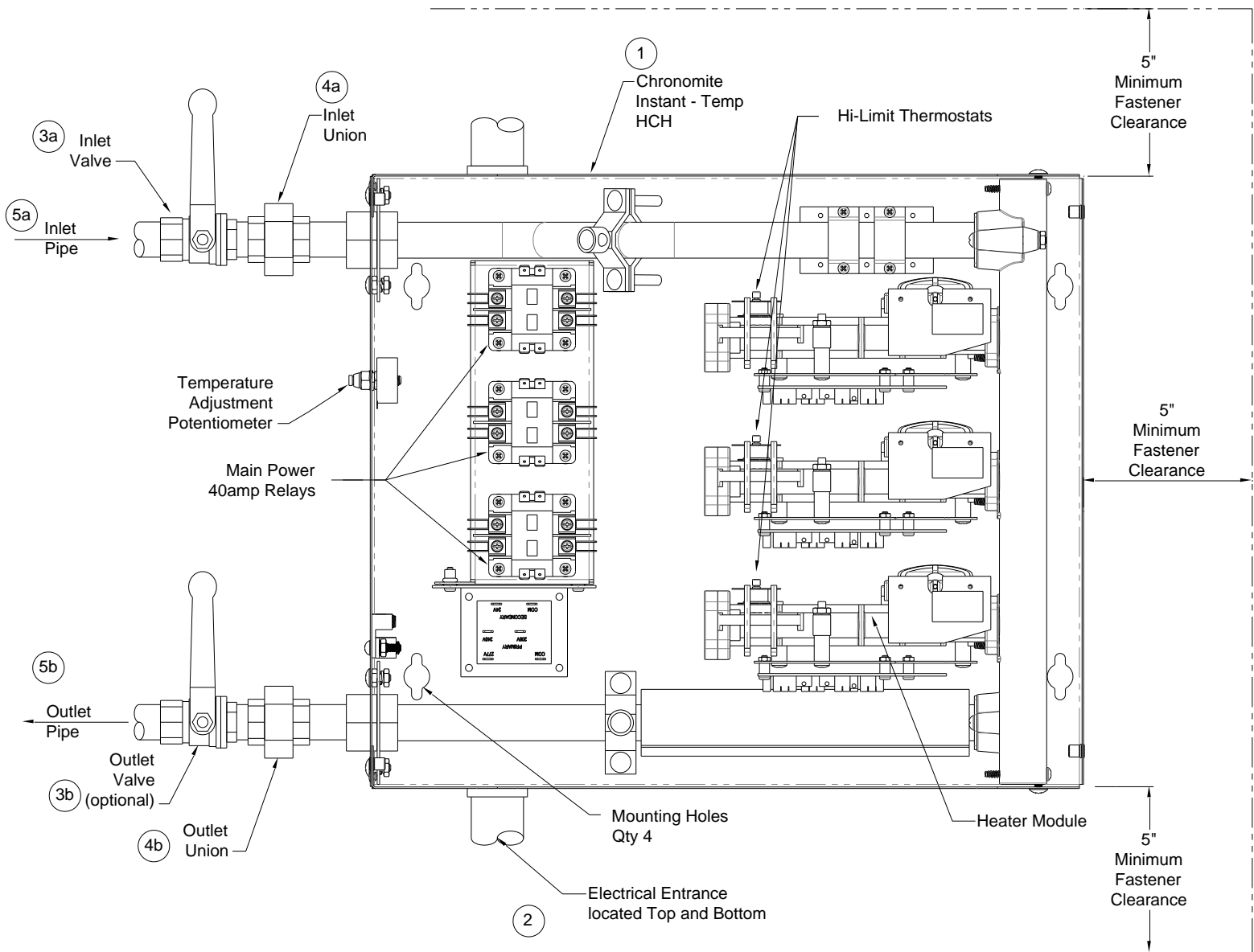

FIGURE 1 - Heater Installation

Items Needed for Installation:

| Item | Part No. | Title | Qty | Description |
|------|----------|-----------------------------------|--------------------|--|
| 1 | ER- | Chronomite Instant-Temp HCH | 1 | See Figure 1 |
| 2 | | Electrical Conduit | Length as required | Enter via Top or Bottom |
| 3a/b | | Inlet / Outlet Valve – 3/4" NPT | 2 | Outlet Valve optional |
| 4a/b | | Inlet / Outlet Union– 3/4" NPT | 2 | |
| 5a/b | | Copper Inlet / Outlet pipe – 3/4" | Length as required | |
| 6 | L-212 | Faucet Flow Control / Dual Thread | 6 | 15/16" Male, 55/64" Female L-212 for (L) Low Activation Models |

Items 1 and 6 are supplied

ELECTRICAL INSTALLATION:

1. Connect power supply wires appropriately sized and protected by single pole circuit breakers to the input terminals on the heater (hard wired) as shown in the Figure 2 wiring diagrams below. Refer to Table 1 above on Page 1 for the voltage, amp and phase ratings of the supply power. Use 2 X 2 wire plus ground supply wires for the 2 module heaters, and 3 X 2 wire plus ground for the 3 module heaters.
2. Ensure each pair of wires are connected to the respective relay terminals. Connect 1 pair at a time.
3. Ensure water inlet/outlet valves are both open.
4. Turn on circuit breaker(s). Turn on water flow to exceed activation point listed in chart 2. Carefully ensure the red LED is illuminated at each circuit board modules. The unit is almost ready for use. Shut off circuit breaker.
5. Check for leaks at all fitting joints and also inside heater.
6. Install cover. Install the (4) cover mounting screws. Turn on circuit breakers. Unit is now ready for use.
7. Local plumbing and electrical codes must be followed in this installation of water heater and the accessories. Failure to comply with code requirements voids warranty.
8. Temperature adjustment potentiometer is standard equipment on (L) Low Activation and (S) Standard Activation models.

Figure 2 - Wiring Connections

2 Module Units / 60-80 amps

A=L1 (Black) B=N (White)

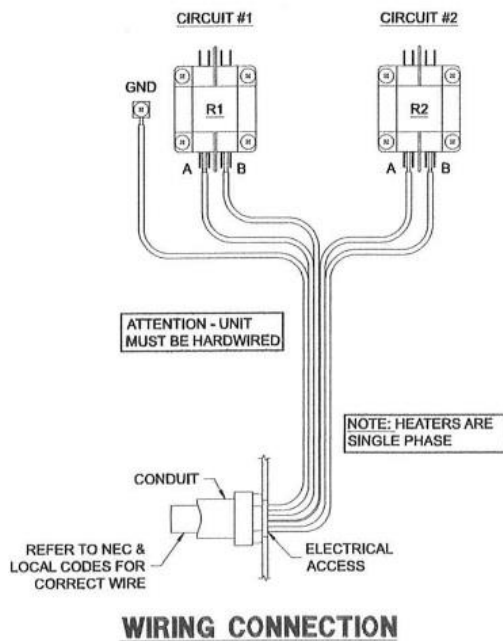

3 Module Units / 90-120 amps

A=L1 (Black) B=N (White)

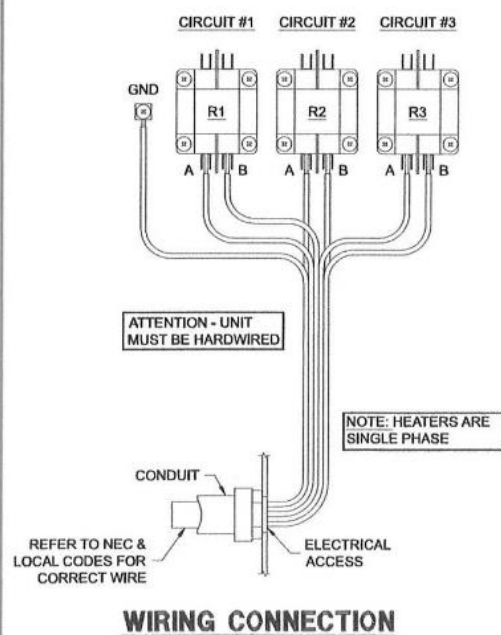

IMPORTANT NOTES: Air in the heater may cause the elements to burn out. If the water lines are serviced or drained upstream of heater, be sure to use the following start up procedure:

1. Turn off electrical supply at circuit breakers.
2. Turn on water supply.
3. Expel all air from lines and heater by cycling downstream faucet 10x.
4. Turn on electrical power supply at circuit breaker.

OPERATION INSTRUCTIONS:

- Turn the hot water faucet to activate the flow switch. See Table 2 for activation chart.
- Cold water can always be mixed when using a two handle faucet.
- The microprocessor will supply the correct amount of power (amperage and voltage) to maintain the outlet temperature at the pre-selected temperature with varying flow rates.
- Once you decrease the flow rate below the GPM activation point, the unit will deactivate.
- Periodically inspect the supply lines, connections and heater for any moisture, corrosion or other potential preventable problems.
- Prior to shutting off water valves for servicing, winterization, etc, always disconnect power from unit 1st.
-

HOW THE HCH INSTANT-TEMP WORKS:

- The engineered plastic case(s) houses a series of ingeniously designed coils that instantly heats water as it flows through the vessel.
- A unique power switch automatically applies electrical current to the coils when hot water is being requested.
- The microprocessor maintains a constant output temperature at the pre-selected temperature.
- The electrical current is not applied to element when the heater is below the activation point or not in use.

FLOW CONTROLS:

You may want to install flow control(s) in your design. The high quality Omni flow controls allow the water heating system to operate more effectively. Call factory for no charge flow controls if needed.

- Low Activation Heaters – Multi Lavatory Installation: L-212 / 0.5 GPM faucet flow control(s) assures the faucet flow rate will not exceed 0.5 GPM per faucet.
- Standard Activation Heaters – Multi Fixture Installation: A-212 / 2.0 GPM faucet flow control(s) assures the faucet flow rate will not exceed 2.0 GPM per faucet.

| Flow Control Models | Type | GPM |
|---------------------|---------------|-----|
| L-212 | Low Flow | 0.5 |
| A-212 | Standard Flow | 2.0 |

FIGURE 3 - Flow Control Installation
Item 6

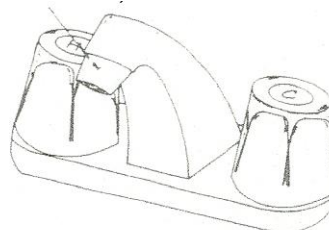

Specifications:

Material: Chrome plated, brass housing.

Threading: Model A212 and L212 have male (outside) threads for Faucets with 15/16" female threads and 55/64" male threads. (See Parts List #6)

Note: Flow controls are adaptable to other thread configurations. Please call factory if an adapter is needed.

Temperature Adjustment Potentiometer - (L) and (S) Activation Models

The potentiometer allows the factory preset temperature of the heater to be changed in the field. The potentiometer will adjust water temperature between 70°F and 125°F provided the wattage of the heater selected is capable of producing the temperature increase at the requested flow rate. See Table 3 temperature chart for each model to determine the temperature range of the heater installed.

When using the potentiometer please use the following operation instructions:

To increase temperature:

- a. Loosen nut
- b. Using a screwdriver, turn screw in small increments clockwise (to the right)
- c. Once temperature of the water is acquired, tighten the nut

To decrease water temperature:

- a. Loosen nut
- b. Using a screwdriver, turn screw in small increments counter clockwise (to the left)
- c. Once temperature is acquired, tighten the nut

Temperature Adjustment - (H) Activation Models

The H model is factory preset for 84°F only and is designed for tepid water use. See Table 3 temperature chart for each model to determine the temperature range of the heater installed.

TABLE 3 – Temperature Rise Chart

2 Module Heaters (60-80 amp)

| Model | Wattage | 1Φ Voltage | °F Temp Rise @ 2.0 GPM | °F Temp Rise @ 3.0 GPM |
|------------------|---------|------------|---------------------------|---------------------------|
| ER-60x/277_16600 | 16,600 | 277 | 57 | 38 |
| ER-80x/277_22200 | 22,200 | 277 | 76 | 50 |

3 Module Heaters (90-120 amp)

| Model | Wattage | 1Φ Voltage | °F Temp Rise @ 3.25 GPM | °F Temp Rise @ 4.25 GPM |
|-------------------|---------|------------|----------------------------|----------------------------|
| ER-90x/277_24900 | 24,900 | 277 | 51 | 39 |
| ER-120x/277_33300 | 33,300 | 277 | 69 | 53 |

Microprocessor limits temperature increase according to the pre-selected outlet temperature

x = (L)-Low Activation
(S)-Standard Activation
(H)-High Activation

TROUBLE SHOOTING GUIDE:

Your High Capacity Instant-Temp water heater has internal user serviceable parts. Contact the factory for guidance on repair or replacement. It can be also returned to the factory for repair or replacement. Please contact factory for return authorization. If after following the Installation Instructions, your HCH Instant-Temp does not heat water in accordance with this literature, please check the following:

1. **Check flow rate** – Controlling flow rate is essential to insure proper temperature rise and heater activation. Check Model for activation type (L), (S), and (H) and refer to Table 2 for flow switch activation points. All relays will engage simultaneously at the activation point. If relays click on, proceed to step 2.
 - a. At 0.35 gpm, it will take approximately 17 seconds to fill a 12 oz. cup of water.
 - b. At 0.80 gpm, it will take approximately 7 seconds to fill a 12 oz. cup of water.
2. **Check Power LED Indicator** – If individual circuit board(s) LED does not illuminate with maximum water flow, check corresponding circuit breaker(s). Control Relay is powered by circuit breaker #1. If no power on #1, remaining modules will not activate.
3. **Low Power** – Make sure of your exact voltage by using a voltmeter. You should obtain your reading off the two box lug terminals on line side of each main relay. Perform this test on each corresponding relay, one at a time. This reading should be approximately 277v for each line side of relay. Compare this reading against the voltage specified in Table 1.
4. **Low Voltage** – The percentage of reduction in voltage will result in a like reduction in temperature rise. Note: 277v models when operated at 254v will have approximately a 15% wattage decrease.
5. **Low Amperage Draw** – Check amperage draw at full water flow using an Amperage probe. Please compare your results with Table 1 to determine if the heater is operating correctly.
6. **High-Limit Thermostat** – Shut off power on all breakers. Remove cover. Push in reset button on each module. Refer to Figure 1 for location(s).
7. **Heater Element(s)** – Shut off power on all breakers. Remove cover. Measure element resistance by using an ohmmeter or multi-meter. Obtain your reading off of one termination rod with brass nut and bottom center tap on each heater module. This reading should be between 6 and 30 ohms for each element.
8. **Length of pipe** – Length of pipe run will affect time to temperature at the faucet. This HCH heater should be mounted strategically when possible to minimize pipe length to the faucet points.
9. **Check Shut-Off Valve(s)** – Check inlet and outlet valves and make sure valve is open 100% to allow full water pressure to heater. Models require a minimum of 25 PSI.
10. **Freezing** – Instant-Temp heaters cannot be installed in a location subject to freezing and must be protected. Winterize if stored in a location subject to freezing. Disconnect power and the inlet/outlet fittings. Blow air through the highest fitting to assist draining. Install RV antifreeze for protection. Failure to winterize will result in freezing and cracking. Re-commission heater start up procedure on page 5.
11. **Problems?** – Call our toll-free hot line (800) 447-4962 or (626) 937-4270.

Exclusive 12-Month Warranty

Your HC Instant-Temp water heater has been engineered and built to the highest quality standards and is backed by a full, factory warranty. Every HC Instant-Temp water heater is guaranteed to be free from defects in material and workmanship for a period of one (1) year from the date of purchase. The above warranty applies to original purchaser if unit is installed following Chronomite Laboratories, Inc.'s Installation Instructions provided. Chronomite Laboratories, Inc. will repair or exchange parts at the factory at no cost. This warranty is limited to repairing or replacing said products which prove to be defective upon factory inspection FOB City of Industry, CA

Exclusion of coverage from this limited warranty:

1. Manufacturer is not liable under this limited warranty or otherwise if the water heater has not been installed or maintained in accordance with manufacturer's printed instructions or installed with improper installation materials. In addition, the water heater or any of its component parts have been subject to misuse, neglect, alteration or accident and the water heater has not been installed in accordance with the applicable local plumbing and or building codes and/or regulations.
2. Manufacturer is not liable for any water damage or other damages arising directly or indirectly from/and defect in the Chronomite tankless water heater component part(s) or from its use.
3. Manufacturer is not liable under this warranty if the water heater has not been continuously supplied with potable water or the water inlet temperature is above manufacturer recommended maximum temperature. In addition, water heater experiences any water pressure or flow interruptions, normal operation inlet water pressure is outside of the published specification (UPC 2009) for the heater, or exposed to any condition that causes the heater to turn on before the air is purged from the heater also known as "dry fire."
4. Manufacturer is not liable if the water heater has been exposed to conditions resulting from floods, earthquakes, winds, fire, freezing, lightning or circumstances beyond the manufacturer's control or the water heater has been removed from its original installation or the water heater has been used for other than the intended purpose.
5. If violation occurs from the stated exclusions of coverage from this limited warranty; owner, and not manufacturer or its agent/representative, is liable for and shall pay for all field charges for labor or other expenses incurred in the removal and/or repair of the water heater or any expense incurred by owner in order to repair the water heater.

**Chronomite Labs, Inc.
17451 Hurley Street,
City of Industry, CA 91744**

Toll Free Technical Hotline: (800) 447-4962 Telephone: (626) 937-4270 Fax: (626)937-4279